

ENGLISH

PLB-2246 13-42 LCD Bracket V1

Ordercode: 100260

Table of contents

Warning	2
Tools required for installing the PLB-2246 13-42 LCD Bracket	3
Safety Instructions	3
Operating Determinations	4
Return Procedure	4
Claims	4
Description of the device	5
Overview	5
Installation	5
Set Up and Operation	5
Wood Stud Wall Mounting	6
Solid Brick and Concrete Block Mounting	6
Maintenance	9
Product Specifications	9

Warning



For your own safety, please read this user manual carefully
before your initial start-up!



Unpacking Instructions

Immediately upon receiving this product, carefully unpack the carton and check the contents to ensure that all parts are present, and have been received in good condition. Notify the dealer immediately and retain packing material for inspection if any parts appear damaged from shipping or the carton itself shows signs of mishandling. Save the carton and all packing materials. In the event that a fixture must be returned to the factory, it is important that the fixture be returned in the original factory box and packing.

Your shipment includes:

- DMT PLB-2246 13-42 LCD Bracket
- User manual

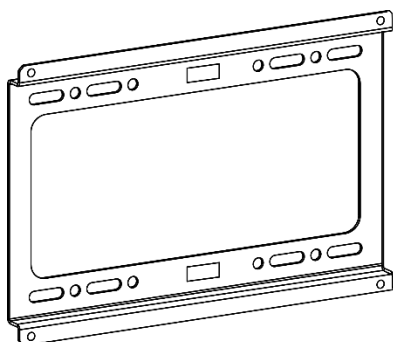

1 x wall plate

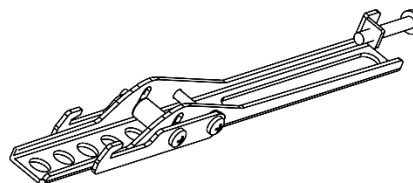

2 x adapter bracket

Wall Kit

4 x concrete anchors (Ø10 Ø6 L50)

4 x lag bolts (ST6.3 x L50)



Monitor Kit

4 x Phillips screws M4 x L35 4 x Phillips screws M6 x L35 4 x spacers (Ø13 Ø8 L20)

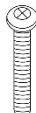

4 x washers Ø6



Bubble level



Tools required for installing the PLB-2246 13-42 LCD Bracket

- Phillips head screwdriver (200 mm length excluding the handle)
- Power drill + 10 mm masonry (concrete) and 3,2 mm (wood) drill bits for wall installation
- Allen wrench
- Marking pen
- Measuring tape
- Level

Safety Instructions

Every person involved with the installation, operation and maintenance of this device has to:

- be qualified
- follow the instructions of this manual



**CAUTION! Be careful with your operations.
Never exceed the maximum load capacity!**



Before your initial start-up, please make sure that there is no damage caused by transportation. Should there be any, consult your dealer and do not use the device.

To maintain perfect condition and to ensure a safe operation, it is absolutely necessary for the user to follow the safety instructions and warning notes written in this manual.

Please consider that damages caused by manual modifications to the device are not subject to warranty.

This device contains no user-serviceable parts. Refer servicing to qualified technicians only.

IMPORTANT:

The manufacturer will not accept liability for any resulting damages caused by the non-observance of this manual or any unauthorized modification to the device.

- Never exceed the maximum load capacity.
- Never remove warning or informative labels from the unit.
- Never lift the bracket, including the flat screen TV, by grabbing the bracket, as the bracket may become damaged. Always remove the flat screen TV first and then remove the bracket.
- Never leave any cables lying around.
- Do not begin the installation of this product before you have read the entire manual.
- Firmly tighten the screws, but do not overtighten. Overtightening can damage the bracket, thereby greatly reducing its holding power.
- When mounting the bracket to wood wall studs, make sure that the mounting screws are anchored into the center of the studs. Use of an "edge to edge" stud finder is highly recommended.
- Please read this manual carefully and keep it for future reference, especially for the required distance from bracket to the wall.
- Always use an assistant or mechanical lifting equipment to safely lift and position your equipment
- Do not shake the device. Avoid brute force when installing the bracket.
- Only use device indoors, avoid contact with water or other liquids.
- Avoid flames and do not put close to flammable liquids or gases.
- Make sure that the supporting surface will safely support the combined load of the equipment and all attached hardware and components.
- Make sure that the device is not exposed to extreme heat, moisture or dust.
- If the bracket is dropped or struck, have a qualified engineer inspect for safety before installing.
- For adult use only. Bracket must be installed by a qualified technician.
- Repairs, servicing and electric connection must be carried out by a qualified technician.
- WARRANTY: Till one year after date of purchase.

Operating Determinations

- The relative humidity must not exceed 50% with an ambient temperature of 40°C.
- If this product is operated in any other way, than the one described in this manual, the product may suffer damages and the warranty becomes void.
- Any other operation may lead to dangers like short-circuit, burns, electric shock, crash etc.

You endanger your own safety and the safety of others!

Improper installation can cause serious damage to people and property !

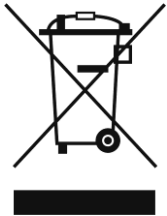

Return Procedure

Returned merchandise must be sent prepaid and in the original packing, call tags will not be issued. Package must be clearly labeled with a Return Authorization Number (RMA number). Products returned without an RMA number will be refused. Highlite will not accept the returned goods or any responsibility. Call Highlite 0031-455667723 or mail aftersales@highlite.nl and request an RMA prior to shipping the fixture. Be prepared to provide the model number, serial number and a brief description of the cause for the return. Be sure to properly pack fixture, any shipping damage resulting from inadequate packaging is the customer's responsibility. Highlite reserves the right to use its own discretion to repair or replace product(s). As a suggestion, proper UPS packing or double-boxing is always a safe method to use.

Note: If you are given an RMA number, please include the following information on a piece of paper inside the box:

- 01) Your name
- 02) Your address
- 03) Your phone number
- 04) A brief description of the symptoms

Claims

The client has the obligation to check the delivered goods immediately upon delivery for any shortcomings and/or visible defects, or perform this check after our announcement that the goods are at their disposal. Damage incurred in shipping is the responsibility of the shipper; therefore the damage must be reported to the carrier upon receipt of merchandise.

It is the customer's responsibility to notify and submit claims with the shipper in the event that a fixture is damaged due to shipping. Transportation damage has to be reported to us within one day after receipt of the delivery.

Any return shipment has to be made post-paid at all times. Return shipments must be accompanied with a letter defining the reason for return shipment. Non-prepaid return shipments will be refused, unless otherwise agreed in writing.

Complaints against us must be made known in writing or by fax within 10 working days after receipt of the invoice. After this period complaints will not be handled anymore.

Complaints will only then be considered if the client has so far complied with all parts of the agreement, regardless of the agreement of which the obligation is resulting.

Description of the device

Features

The PLB-2246 13-42 LCD Bracket is a bracket for flat screen TVs.

- Fixed wall mount
- Maximum load: 25 kg
- Screen size: 13" - 42"
- Max. VESA: 75 x 75 to 200 x 200 mm
- Tilt adjustment: 0-6°
- Weight: 2,5 kg

Overview

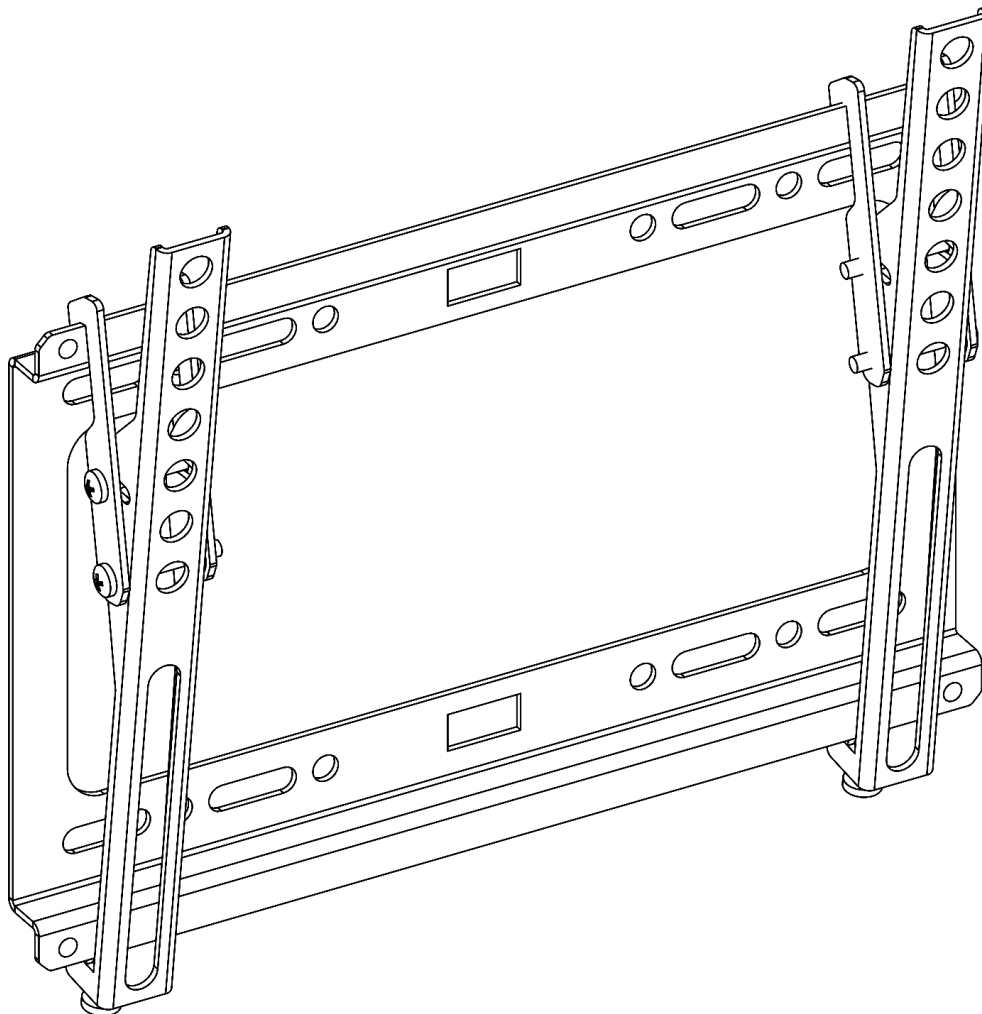

Fig. 01

Installation

Remove all packing materials from the PLB-2246 13-42 LCD Bracket. Check that all foam and plastic padding is removed. Connect all cables.

Do not supply power before the whole system is set up and connected properly.

Always disconnect from electric mains power supply before cleaning or servicing.

Damages caused by non-observance are not subject to warranty.

Set Up and Operation

Follow the directions below, as they pertain to your preferred operation mode.

Wood Stud Wall Mounting

- Use a 3,2 mm drill bit (wood) to drill the holes (hole size: 3,2 mm, hole depth: 60 mm).

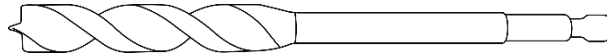

- Make sure that the supporting surface will safely support the combined load of the equipment and all attached hardware and components.
- Firmly tighten the woodscrews, but do not overtighten. Overtightening can damage the bracket, thereby greatly reducing its holding power.
- When mounting the bracket to wood wall studs, make sure that the mounting screws are anchored into the center of the studs. Use of an "edge to edge" stud finder is highly recommended.
- The provided hardware is for mounting through or attachment to a standard thickness drywall or plaster into studs. Installers are responsible for providing the hardware for other types of mounting situations.

Solid Brick and Concrete Block Mounting

- Use a 10 mm drill bit (concrete) to drill the holes (hole size: 10 mm, hole depth: 60 mm).



- When installing the wall mounts on a cinderblock, verify that you have a minimum of 1-3/8" of actual concrete thickness in the hole to be used for the concrete anchors.
- Do not drill into mortar joints!
- Be sure to mount on a solid part of the block, with a 1" minimum from the side of the block. You should use an electric drill at low speed to drill the hole, instead of a hammer drill to avoid breaking out the back of the hole when entering a void or cavity.
- The installer must verify if the supporting surface will safely support the combined load of the equipment and all attached hardware and components.
- Use the wall bracket as a template to mark the holes on the wall.

01) Use a level to mark the drilling location of the wall plate (for wood studs, please detect the center with a stud finder). Make sure that the alignment is correct.

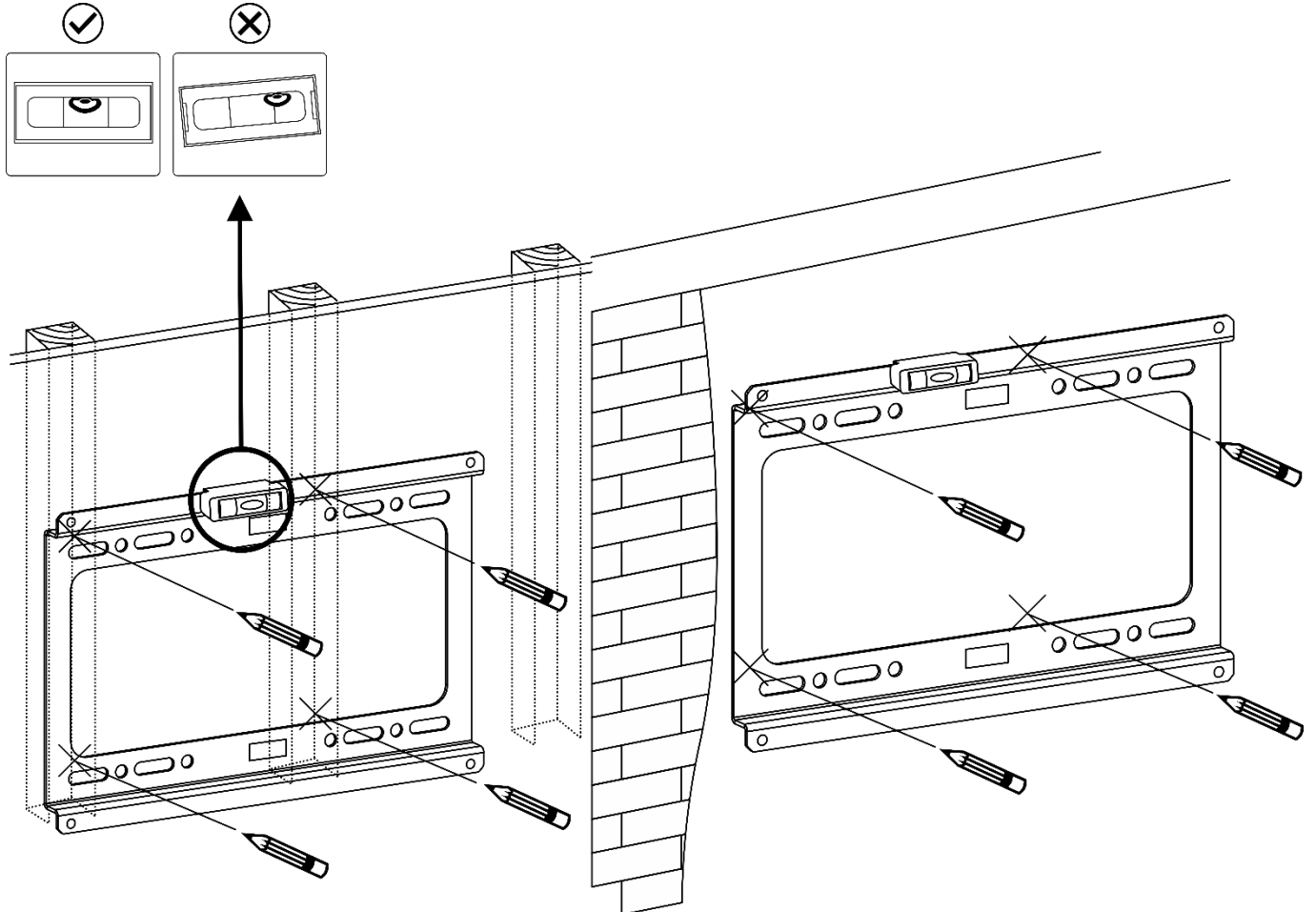

02) Drill pilot holes at marked locations. Gently hammer the anchors in. (The anchors should be used only in case of solid brick or concrete block mounting. In case of wood stud mounting, the anchors are not needed.)

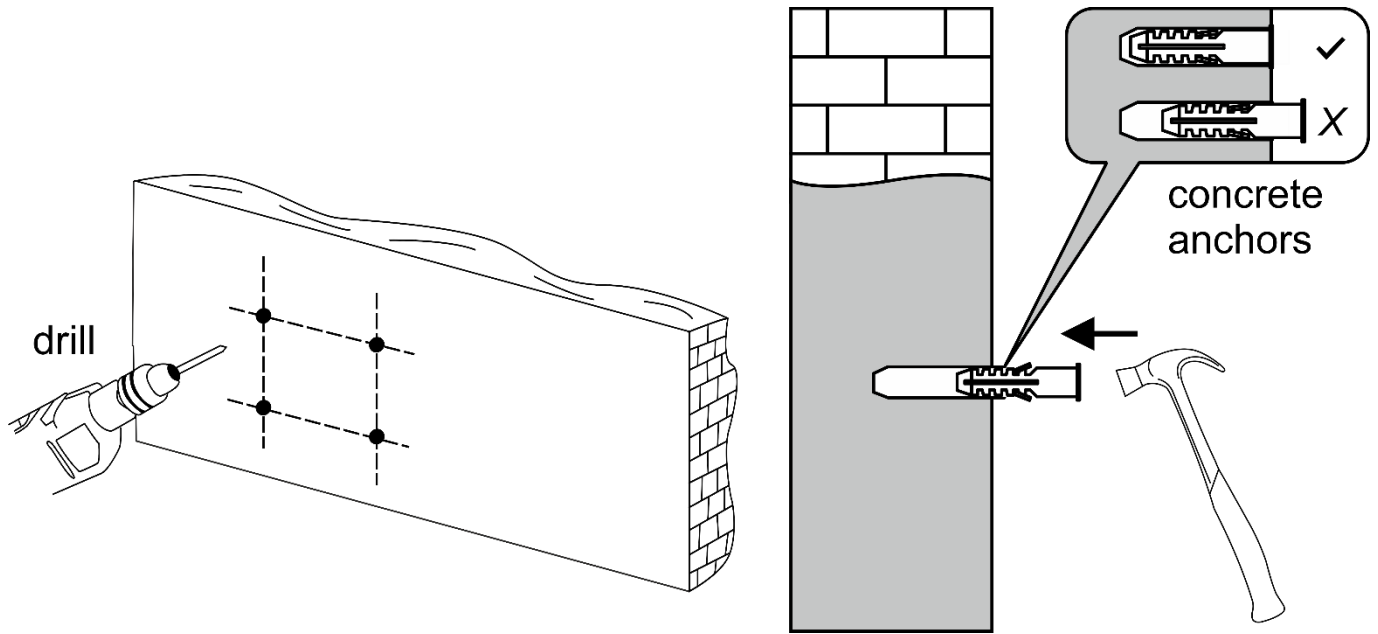

	wood wall	wood stud	concrete
Pilot Hole Size	3,2 mm	3,2 mm	10 mm
Pilot Hole Depth	Through	60 mm	60 mm

03) Insert the lag bolts, through the wall plate, into the drilled holes. Tighten the screws with an Allen wrench.

Wood

Anchors are not needed

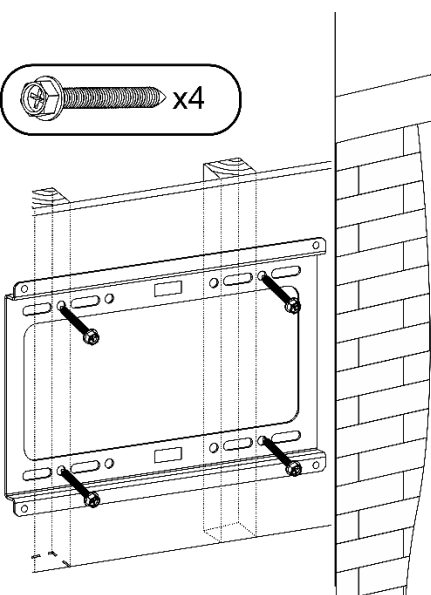
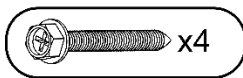

Concrete

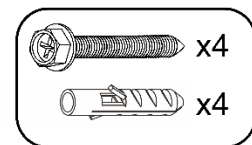
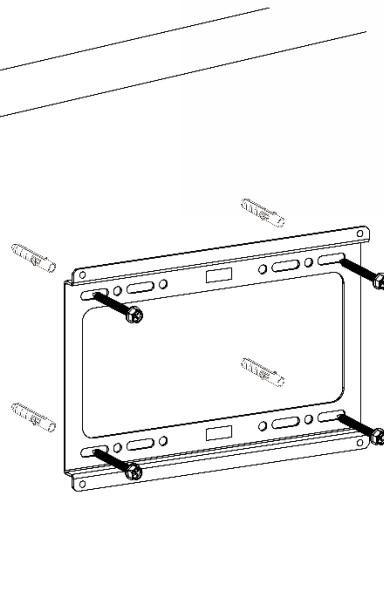

04) Attach the adapter brackets to the VESA holes. Select the screws appropriate for your TV. If needed, use the included spacers and washers. Tighten the screws with a screwdriver.

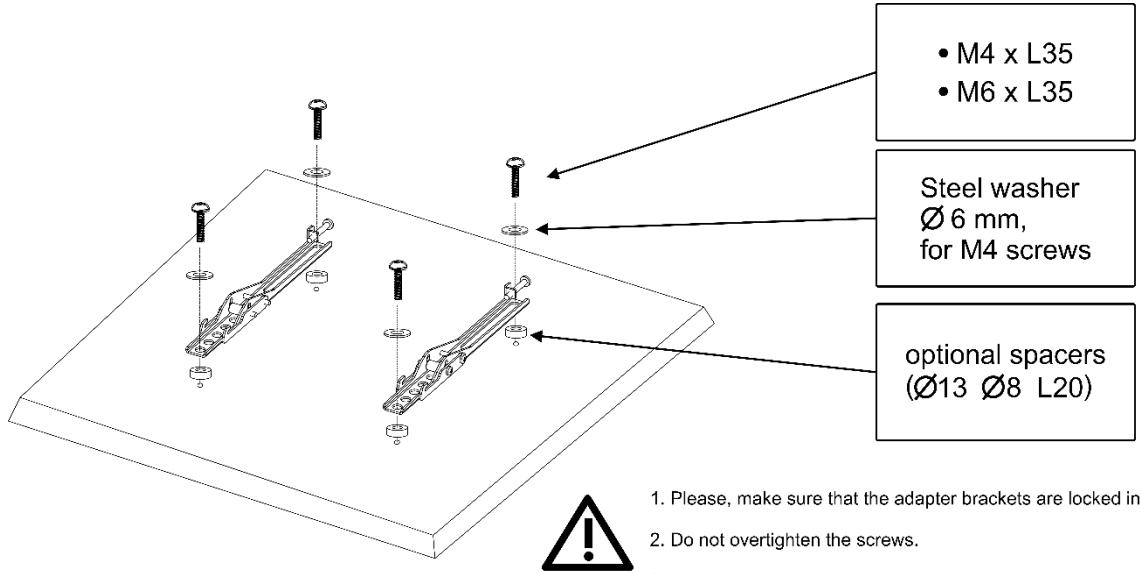

1. Please, make sure that the adapter brackets are locked in the VESA holes on your TV.
2. Do not overtighten the screws.
3. Make sure that the screws are not longer than the threaded holes.

05) Once the wall plate has been secured to the wall, carefully lift your TV (**with 2 people**) and hook the top hooks over the top of the wall plate rail, as shown below.

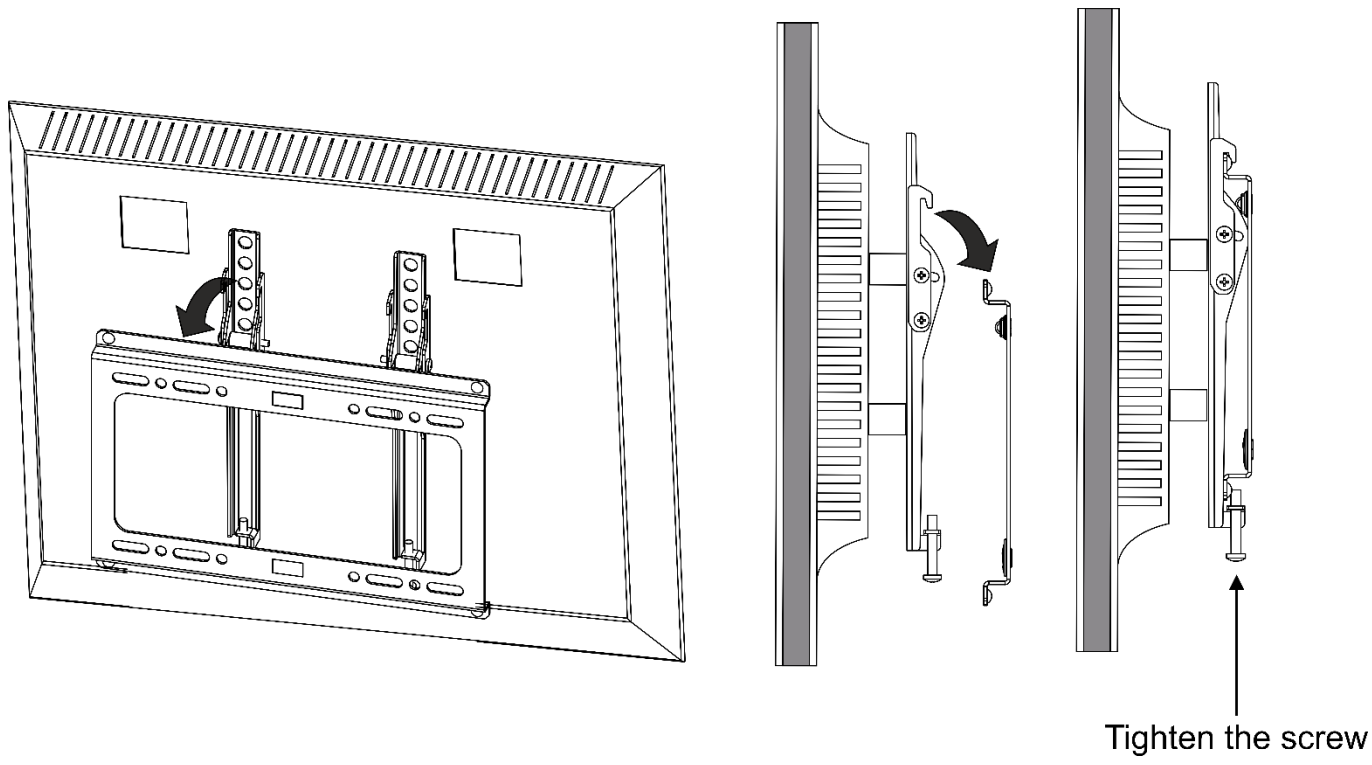

06) Loosen the screws on the bracket and tilt the TV to the desired angle.

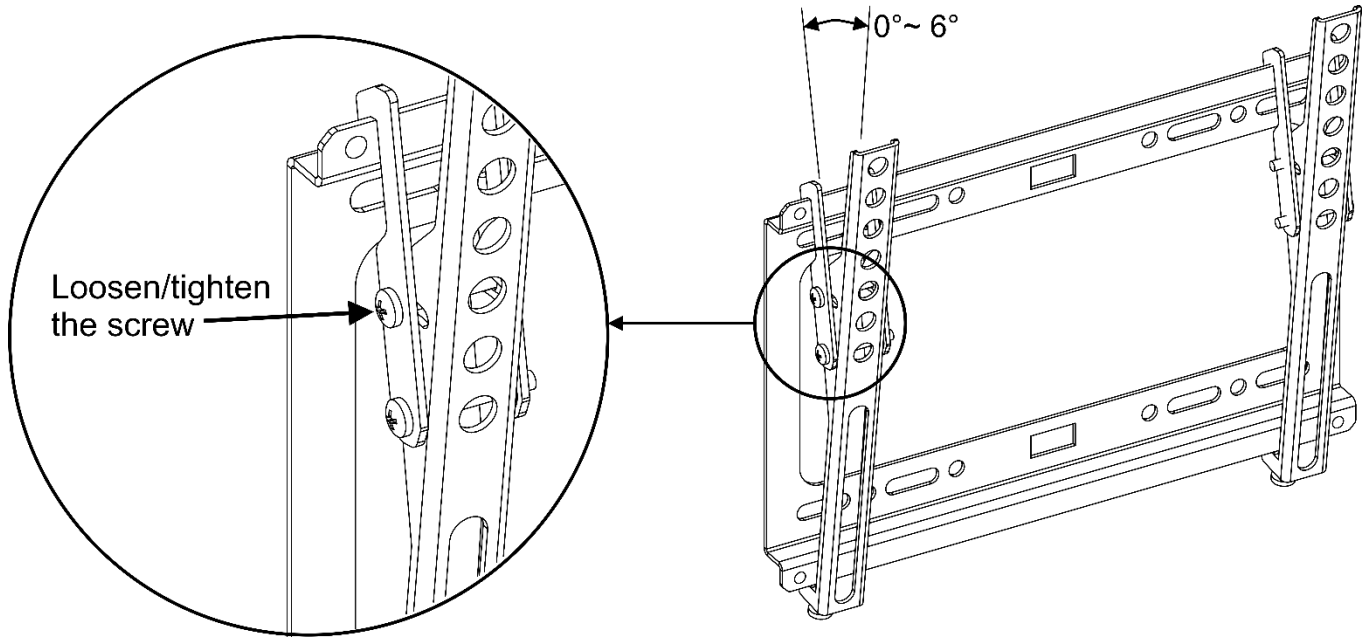

07) Tighten the screws.

Maintenance

The operator has to make sure that safety-related and machine-technical installations are to be inspected by an expert after every year in the course of an acceptance test.

The operator has to make sure that safety-related and machine-technical installations are to be inspected by a skilled person once a year.

The following points have to be considered during the inspection:

- 01) All screws used for installing the device or parts of the device have to be tightly connected and must not be corroded.
- 02) There may not be any deformations on housings, fixations and installation spots.
- 03) Mechanically moving parts like axles, eyes and others may not show any traces of wearing.
- 04) The electric power supply cables must not show any damages or material fatigue.

Product Specifications

Model:	DMT PLB-2246 13-42 LCD Bracket
Maximum load:	25 kg
Screen size:	13" - 42"
Max. VESA:	75 x 75 to 200 x 200 mm
Weight:	2,5 kg

Design and product specifications are subject to change without prior notice.



Website: www.DutchMediaTools.info

Email: service@highlite.nl



©2017 DMT