

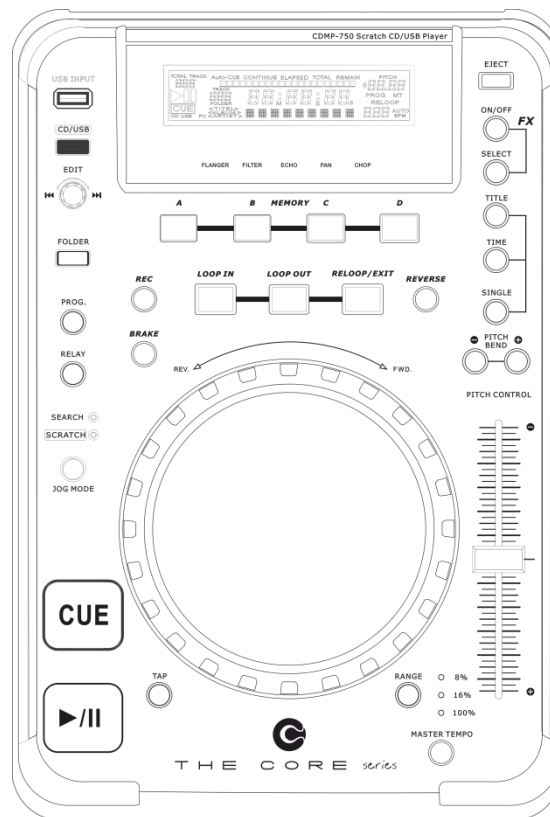

MANUAL



ENGLISH

CDMP-750

V1

Ordercode: D1155

Table of contents

| | |
|---|----|
| Warning | 2 |
| Unpacking Instructions | 2 |
| Safety Instructions | 2 |
| Operating Determinations | 3 |
| Return Procedure | 4 |
| Claims | 4 |
| Description of the device | 5 |
| Features | 5 |
| Overview | 5 |
| Frontside | 7 |
| Backside | 7 |
| Installation | 7 |
| Set Up and Operation | 7 |
| Functions | 8 |
| Operations | 13 |
| Loading a CD | 13 |
| Unloading a CD | 13 |
| Selecting tracks | 13 |
| Starting playback | 13 |
| Stop playback | 14 |
| Pausing | 14 |
| Setting a cue point | 14 |
| Setting a hot cue Point | 14 |
| Cueing | 14 |
| Frame search | 15 |
| Scanning | 15 |
| Time display | 15 |
| Changing pitch of the song | 15 |
| Program play | 16 |
| Loop play | 16 |
| Set auto loop length | 16 |
| Auto loop play | 16 |
| Reloop | 16 |
| Creating a hot loop | 17 |
| Relay play (two CD players) | 17 |
| Before switching off the power | 17 |
| CDs | 17 |
| Precaution on storage | 17 |
| Maintenance | 18 |
| Troubleshooting | 18 |
| Product Specifications | 19 |
| Dimensions | 20 |
| Notes | 21 |

Warning



**For your own safety, please read this user manual carefully
before your initial start-up!**



Unpacking Instructions

Immediately upon receiving this product, carefully unpack the carton and check the contents to ensure that all parts are present, and have arrived in good condition. Notify the dealer immediately and retain packing material for inspection if any parts appear damaged while shipping or the carton itself shows signs of mishandling. Save the carton and all packing materials. In the event that a fixture must be returned to the factory, it is important that the fixture be returned in the original factory box and packing.

Your shipment includes:

- DAP CDMP-750
- Power cable (170 cm)
- RCA Male cable L/R > RCA Male cable L/R (50 cm)
- User manual

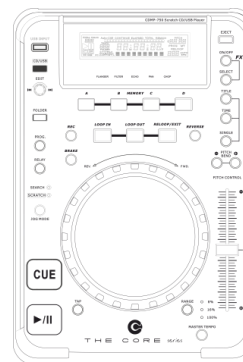

CAUTION!

**Keep this device away from rain and moisture!
Unplug mains lead before opening the housing!**



**CAUTION! Be careful with your operations.
With a dangerous voltage you can suffer
a dangerous electric shock when touching the wires!**



Safety Instructions

Every person involved with the installation, operation and maintenance of this system needs to:

- be qualified
- follow the instructions of this manual

Before the initial start-up, please make sure that there is no damage caused by transportation. Should there be any, consult your dealer and do not use the system.

To maintain perfect condition and to ensure a safe operation, it is absolutely necessary for the user to follow the safety instructions and warning notes written in this manual.

Please consider that damages caused to the system by manual modifications are not subject to warranty.

This system contains no user-serviceable parts. Refer servicing to qualified technicians only.

IMPORTANT:

The manufacturer will not accept liability for any resulting damages caused by the non-observance of this manual or any unauthorized modification to the system.

- Never let the power cord come into contact with other cables! Handle the power cord and all connections with the mains with particular caution!
- Never remove warning or informative labels from the unit.
- Never use anything to cover the ground contact.
- Never leave any cables lying around.
- Do not insert other objects than CDs in the CD slot.
- Do not connect this system to a dimmerpack.
- Do not switch the system on and off in short intervals, as this may reduce the unit's lifespan.
- Do not open the device and do not modify the device.
- Only use system indoor, avoid contact with water or other liquids.
- Avoid flames and do not store in the vicinity of flammable liquids or gases.
- Always disconnect power from the mains when the unit is not used. Only handle the power cord by the plug. Never pull out the plug by tugging the power cord.
- Make sure you do not use the inappropriate kind of cables or defective cables.
- Make sure that the available voltage is not higher than stated on the rear panel.
- Make sure that the power cord is never crimped or damaged. Check the system and the power cord from time to time.
- Please turn off the power switch, when changing a signal cable.
- If the device is dropped or struck, disconnect mains power supply immediately. Have a qualified engineer inspect for safety before operating.
- If the device has been exposed to drastic temperature fluctuation (e.g. after transportation), do not switch it on immediately. The arising condensation might damage your system. Leave the system switched off until it has reached room temperature.
- If your Dap Audio device fails to work properly, discontinue use immediately. Pack the unit securely (preferably in the original packing material), and return it to your Dap Audio dealer for service.
- Repairs, servicing and electric connection must be carried out by a qualified technician.
- For replacement use fuses of same type and rating only.
- WARRANTY: Until one year from date of purchase.

Operating Determinations

This system is not designed for permanent operation. Consistent operation breaks will ensure that the system will serve for a longer amount of time without defects.

If this system is operated in any other way than the one described in this manual, the product may suffer damages and the warranty can become void.

Any other operation may lead to various hazards like short-circuit, burns, electric shock, etc.

You endanger your own safety and the safety of others!

Improper installation can cause serious injuries and/or damage of property !



Return Procedure



Returned merchandise must be sent prepaid and in the original packing, call tags will not be issued. Package must be clearly labeled with a Return Authorization Number (RMA number). Products returned without an RMA number will be refused. Highlite will not accept the returned goods or any responsibility. Call Highlite 0031-455667723 or mail aftersales@highlite.nl and request an RMA prior to shipping the device. Be prepared to provide the model number, serial number and a brief description of the cause for the return. Be sure to properly pack the device, any shipping damage resulting from inadequate packaging is the customer's responsibility. Highlite reserves the right to use its own discretion to repair or replace product(s). As a suggestion, proper UPS packing or double-boxing is always a safe method to use.

Note: If you are given an RMA number, please include the following information on a piece of paper inside the box:

- 01) Your name
- 02) Your address
- 03) Your phone number
- 04) A brief description of the symptoms

Claims

The client has the obligation to check the delivered goods immediately upon delivery for any shortcomings and/or visible defects, or perform this check after our announcement that the goods are at their disposal. Damage incurred in shipping is the responsibility of the shipper; therefore the damage must be reported to the carrier upon receipt of merchandise.

It is the customer's responsibility to notify and submit claims with the shipper in the event that a device is damaged due to shipping. Transportation damage has to be reported to us within one day after receipt of the delivery.

Any return shipment has to be made post-paid at all times. Return shipments must be accompanied with a letter defining the reason for return shipment. Non-prepaid return shipments will be refused, unless otherwise agreed in writing.

Complaints against us must be made known in writing or by fax within 10 working days after receipt of the invoice. After this period complaints will not be handled anymore.

Complaints will only then be considered if the client has so far complied with all parts of the agreement, regardless of the agreement of which the obligation is resulting.

Description of the device

Features

The CDMP-750 is a professional DJ CD/MP3 Player from DAP Audio.

- LCD display with blue backlight
- Pitch control +/- 8/16/100%
- Electronic anti shock buffer (15 seconds)
- Seamless loop function
- Beat related auto loop function
- Scratch function
- Cue function
- 5 digital BPM related effects
- 4 memories for hotloops or cues
- Program function
- USB stick/hard disk port
- Relay function
- Adjustable brake and start time
- Master tempo function
- Reverse play
- Auto BPM function

Overview

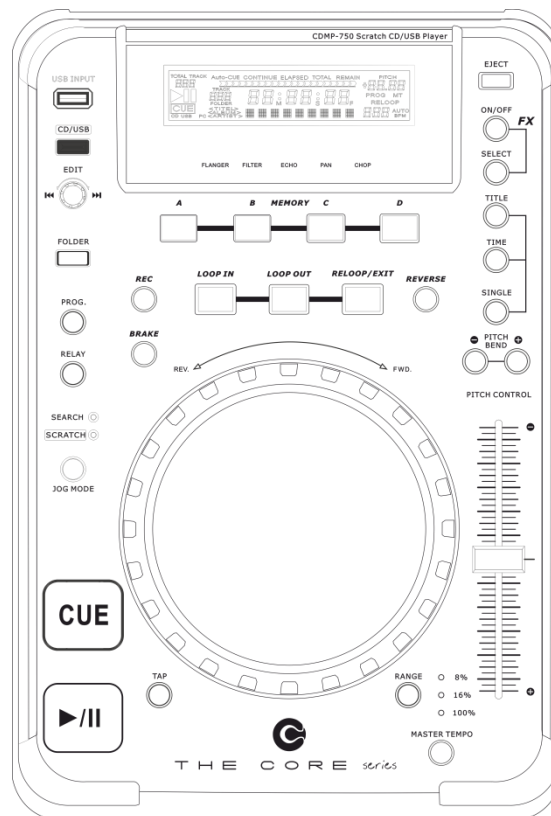

Fig. 01

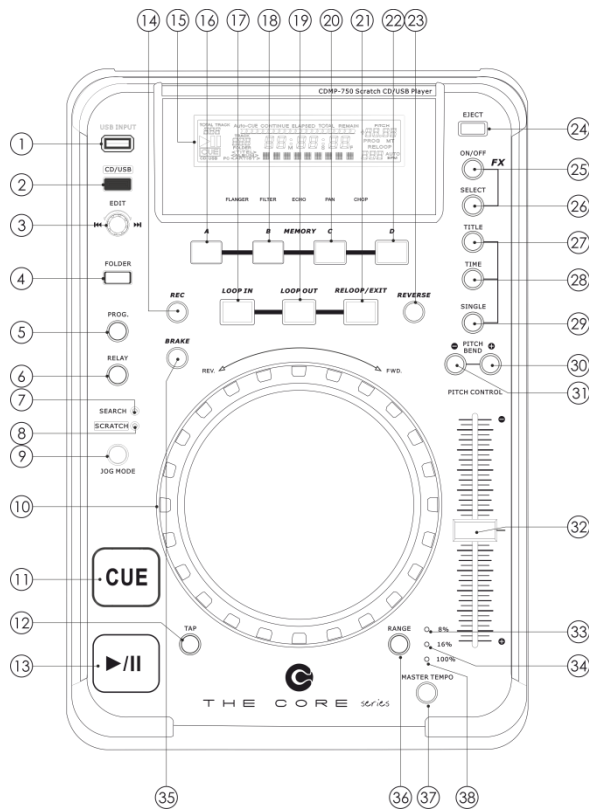
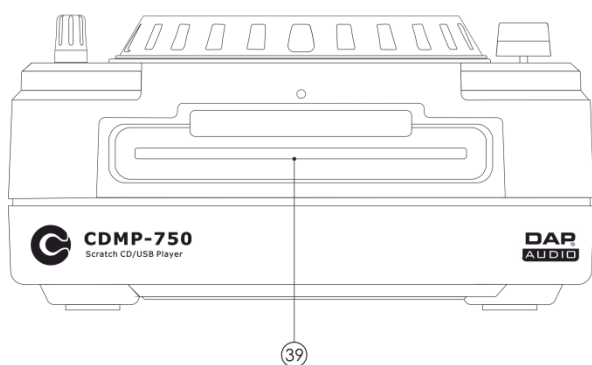

Fig. 02

- | | |
|---------------------------|-------------------------|
| ① USB port | ②① Memory C button |
| ② CD/ USB button | ②② Reeloo/ Exit |
| ③ Edit ◀◀ / ▶▶ encoder | ②③ Memory D button |
| ④ Folder button | ②④ Reverse button |
| ⑤ Prog. button | ②⑤ Eject button |
| ⑥ Relay button | ②⑥ FX on/off button |
| ⑦ Search LED | ②⑦ FX select button |
| ⑧ Scratch LED | ②⑧ Title button |
| ⑨ Jogmode button | ②⑨ Time button |
| ⑩ Jog wheel | ③① Single button |
| ⑪ Cue button | ③② Pitch + Button |
| ⑫ Tap button | ③③ Pitch - Button |
| ⑬ Play/ Pause ▶/ button | ③④ Pitch control fader |
| ⑭ Rec button | ③⑤ Pitch range 8% LED |
| ⑮ LCD Display | ③⑥ Pitch range 16% LED |
| ⑯ Memory A button | ③⑦ Brake button |
| ⑰ Loop In button | ③⑧ Range button |
| ⑱ Memory B button | ③⑨ Master tempo button |
| ⑲ Loop Out button | ④① Pitch range 100% LED |

Frontside



Backside

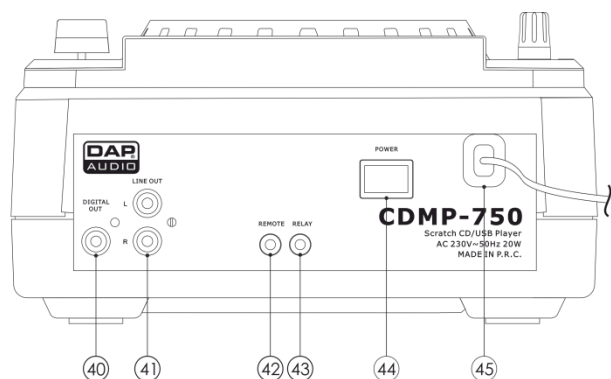

Fig. 03

- ③⑨ Disc Slot
- ④⑩ Digital out
- ④① Line out L/R
- ④② Remote jack
- ④③ Relay jack
- ④④ Power switch
- ④⑤ Power cord

Installation

Remove all packing materials from the CD Player. Check if all the foam and plastic padding is removed. Connect all cables.

Always disconnect from electric mains power supply before cleaning or servicing.
Damages caused by non-observance are not subject to warranty.

Set Up and Operation

Before plugging the unit in, always make sure that the power supply matches the product specification voltage. The power supply is printed on the backside of the device.
 Do not attempt to operate a 120V specification product on 230V power, or vice versa.

Connections:

- 01) Turn off the **Power switch (44)**.
- 02) Connect the **Line out L/R (41)** outputs to the input of your mixer.

CAUTION: Ensure that the power is off while connecting the cables.

Functions

Names and Functions

Below is a description of the control functions.

01) USB port

Use this port to connect a USB stick or an external hard disk. The USB port is only active when you're in USB mode.

Note: The CDMP-750 can handle a maximum of 2 Tbyte, 999 folders and 999 files.

02) CD/ USB button

Use this button to select CD mode or USB mode.

03) Edit ►/◄ encoder

This encoder has a dual function, in normal mode turning the encoder clockwise allows you to skip a previous track, while turning counterclockwise will skip a following track.

Depending on the mode you are in, the edit encoder can also be used for: adjusting the loop length, selecting folders or selecting a playlist format.

Clicking the edit encoder allows you to enter certain parameters.

For more info, see the chapter on operations on page 12.

04) Folder button

Press this button to open the folder menu. While in the folder menu, the folder will appear in the display. Select a folder by rotating the **Edit encoder (03)** and open the folder by pressing the **Edit encoder (03)**.

05) Prog. button

This button allows you to toggle the program mode on or off. See page 15, **Program play**.

06) Relay button

Pressing this button allows you to toggle the relay mode on or off. If the FX section is switched in, this button allows you to toggle between gain and parameter.

07) Search LED

Indicates that the CDMP-750 is in search mode. See page 14, **Frame search**.

08) Scratch LED

Indicates that the CDMP-750 is in scratch mode. In scratch mode, you can use the jog wheel for scratch effects.

09) Jog mode button

Pressing the jog mode button allows you to select search mode - indicated by the **Search LED (07)** button, scratch mode - indicated by the **Scratch LED (08)** button or normal mode (no LED lit).

If none of the modes is active, the **Jog wheel (10)** is in pitch bend mode. If there is no **Jog wheel (10)** action while in search mode for 10 seconds, the unit will return to normal (pitch bend) mode.

10) Jog wheel

The jog wheel is used for setting cues, scratch effects and performing a fast search depending on the mode the unit is in.

11) Cue button

Press this button during playback to return to the position at which playback started.

12) Tap button

Tap this button to determine the BPM of the music manually.

Press and hold this button to start auto BPM mode.

13) Play/ Pause ►/|| button

This button allows you to toggle between pause mode and playback mode.

14) Rec button

Pressing this button allows you to store a Hot Loop or a Hot Cue.

Pressing and holding the **Rec (14)** button and turning the **Jog wheel (10)** allows you to set the length of the auto Loop.

After the auto loop length is set, the **Rec (14)** button will light up, indicating that the unit is ready to execute the auto loop playback. Pressing the **Loop In (17)** button will automatically start and finish the loop with the length previously set up. The bar length of auto loop can be selected from 1/32 to 32/1. During loop playback, turning the **Edit encoder (03)** allows you to (re)adjust the loop length.

15) LCD Display

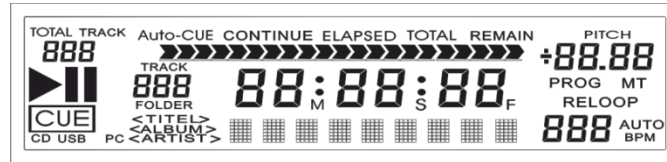

Fig. 04

TOTAL TRACK: Shows the current track number or the folder number while selecting folders.

▶: Indicates that the unit is in playback mode

|| : Indicates that the unit is in pause mode

CUE: indicates that a cue point has been memorized.

CD: Indicates that the unit is in CD mode.

USB: Indicates that the unit is in USB mode.

PC: No function in the CDMP-750.

CONTINUE: When lit, the unit is in continuous play mode and will not stop after each track.

ELAPSED: Shows the actual playing time.

TOTAL: Shows the total playing time for a whole CD.

REMAIN: Shows how much time is left for the track playing at this moment.

TIME BAR: Indicates playing time.

TRACK: Shows a track number.

MINUTES: Shows elapsing or remaining time, depending on time mode setting.

SECONDS: Shows elapsing or remaining seconds, depending on time mode setting.

FRAMES: The CD Player breaks down a second into 75 frames for accurate cueing. This shows the elapsing or remaining frames, depending on mode setting.

MODE DISPLAY: The mode display consists of 9 alphanumeric characters just beneath time display and shows useful information such as: FX parameters, MP3 file's name and folder number etc.

Folder name will not be displayed.

PITCH: Indicates the current pitch.

PROG: Lights up to indicate that there is a program list existing in normal playback. Blinks when a program list is running.

MT: Lights up when performing master tempo function.

RELOOP: Lights up when performing the loop function.

888 BPM: Shows BPM value.

AUTO: Indicates that the AUTO BPM function is activated.

16) Memory A button

This button allows you to store a hotloop and/or a hotcue in memory A.

17) Loop In button

This button allows you to set the start point for the loop.

18) Memory B button

This button allows you to store a hotloop and/or a hotcue in memory B.

19) Loop Out button

The loop out button allows you to set the end point for the loop. Pressing the button again, allows you to edit the loop.

20) Memory C button

This button allows you to store a hotloop and/or a hotcue in memory C.

21) Re loop/ Exit button

Press this button to either exit or call the Loop playback.

22) Memory D button

This button allows you to store a hotloop and/or a hotcue in memory D.

23) Reverse button

Use this button to toggle the reverse mode on or off. In reverse mode, the built in LED will light up and the current track will be played backwards.

24) Eject button

Press this button to open and close the disc holder. The disc holder can't be opened during

playback, so stop playback before pressing the button.

25) FX On/Off button

This button allows you to toggle the effect processor on or off. Press the **Relay (06)** button to switch between gain and parameter. Once gain is selected, the button will light up and show the gain value on the **LCD display (15)** will show the gain value blinking. If the parameter is selected, the **Relay (06)** button will blink, just like the parameter value on the **LCD display (15)**.

26) FX Select button

Pressing this button allows you to select one of the five effects as shown below.

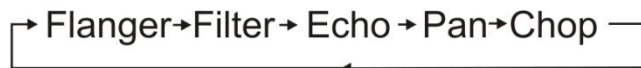

Fig. 05

27) Title button

Pressing this button allows you to select one of the four display modes (MP-3 only) as shown below.



Fig. 06

Pressing and holding allows you to turn a playlist format using the **Edit encoder (3)**. Releasing this button results in entering the selected format.



Fig. 07

28) Time button

Press this button to switch the TIME indication on the **LCD display (15)** between the elapsed time and remaining time. The selected mode is indicated by the ELAPSED or REMAIN.

29) Single button

Press this button to switch between the auto-cue mode and continuous play mode.

The selected mode is indicated by respectively Auto-CUE or CONTINUE in the **LCD display (15)**.

In auto-cue mode, the unit stops playing after each track.

In continuous play mode, the unit plays all tracks and then stops.

30) Pitch Bend + button

The CD speeds up while pressing and holding this button. Release the button to return to the original BPM.

31) Pitch Bend – button

The CD slows down while using and holding this button. Release the button to return to the original BPM.

32) Pitch Control Fader

Use this fader to adjust the pitch. Move the fader upwards to decrease the pitch, move the fader downwards to increase the pitch.

33) Range 8% LED

Indicates that the maximum range for the **Pitch control fader (32)** is $\pm 8\%$.

34) Range 16% LED

Indicates that the maximum range for the **Pitch control fader (32)** is $\pm 16\%$.

35) Brake button

Pressing and holding this button while turning the jog wheel allows you to set the start/break time between 0,5 and 6 seconds. Arm the brake function by pressing the **Brake (35)** button, the **Brake (35)** button lights up red indicating the brake function is armed. Pressing the **Play/Pause (13)** button will actually trigger the start/break function.

36) Range button

Pressing this button allows you to change the maximum range for pitch control and lets you select a range of $\pm 8\%$, $\pm 16\%$ or $\pm 100\%$.

37) Master tempo button

Allows you to toggle the master tempo mode on or off. When master tempo mode is active, the button will light up in red. While master tempo mode is active, the pitch fader allows you to shift the pitch of the song played back while the tempo of the song stays the stays unchanged.

38) Range 100% LED

Indicates that the maximum range for the **Pitch control fader (32)** is $\pm 100\%$.

39) Disc slot

Place the disc gently in the slot. The disc will load automatically. Stop playback and press the **Eject (24)** button to eject the disc.

40) Digital out

Digital output for connecting to a digital mixer.

41) Line out L/R

RCA stereo line output.

42) Remote jack

Use a 3,5mm mono jack cable to connect this input to the fader start output on a mixer for remote control of the **Play/Pause (13)** button.

43) Relay jack

Use a 3,5mm mono jack cable to connect the relay jacks of two CDMP-750's to enable relay play.

44) Power switch

This is the main power switch. Press to turn the device on.

45) Power cord

Connect the CDMP-750 to a 230Vac wall socket only.

Operations

Loading a CD

Hold the disc by the edges and Press it gently in the **Disc Slot (39)**. The Disc will now be loaded automatically.

Unloading a CD

- 01) The disc can't be ejected during playback. Stop the playback first.
- 02) Press the **Eject (24)** button. The disc will be ejected.
- 03) If the movement of the disc stops, take the disc by the edges and remove it completely from the slot.

CAUTION:

- Do not place any foreign objects in the disc slot and do not try to place more than one disc in the disc slot at a time.
- Do not press the disc in manually when the power is off, as this may damage the player.

Selecting tracks

- 01) Turn the **Edit encoder (03)** clockwise to move to a higher track number.
- 02) Turn the **Edit encoder (03)** counterclockwise to move to a lower track number.
- 03) When a new track is selected during playback, playback begins as soon as the skip search operation is completed.
- 04) If you turn the **Edit encoder (03)** clockwise while at the last track, the first track will be selected. The same way, if you turn the **Edit encoder (03)** counterclockwise while at the first track, the last track will be selected.

Starting playback

- 01) Press the **Play/Pause (13)** button during the pause or cue condition to start playback mode, the **Play/Pause (13)** button lights up green.
- 02) The point at which playback starts is automatically stored in the memory as the cue point. The CD player returns to the cue point when the **Cue (11)** button is pressed.

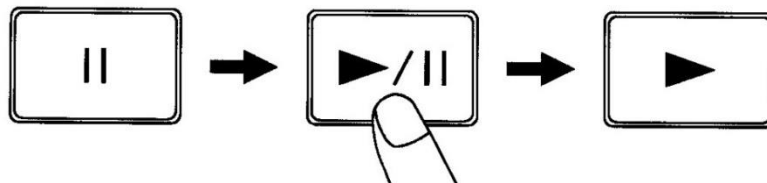

Fig. 08

Stop playback

There are two ways to stop playback:

- 01) Press the **Play/Pause (13)** button during playback mode to pause at that point.
- 02) Press the **Cue (11)** button during playback to return to the cue point and enter pause mode.

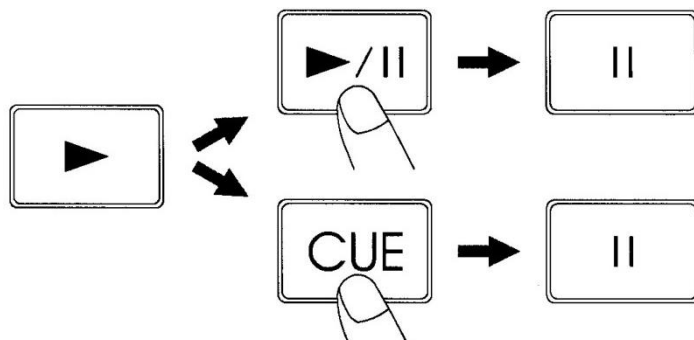

Fig. 09

Pausing

- 01) Press the **Play/Pause (13)** button to switch between play and pause.
- 02) The **Play/Pause (13)** button and the **Cue (11)** button will flash when the unit is in pause mode.
- 03) Playback resumes when the **Play/Pause (13)** button is pressed again.

Setting a cue point

- 01) Press the **Play/Pause (13)** button to switch between play and pause.
- 02) The **Play/Pause (13)** button and the **Cue (11)** button will flash when the unit is in pause mode.
- 03) Turn the **Jog wheel (10)** to go to your desired cue point (if necessary).
- 04) Press the **Play/Pause (13)** button again and your cue point has been stored and playback will continue.

Setting a hot cue Point

- 01) Press the **Play/Pause (13)** button to switch between play and pause.
- 02) The **Play/Pause (13)** button and the **Cue (11)** button will flash when the unit is in pause mode.
- 03) Press the **Rec (14)** button, all four hot cue buttons (**A (16)**, **B (18)**, **C (20)** or **D (22)**) will light up in red.
- 04) Press the hot cue button (**A (16)**, **B (18)**, **C (20)** or **D (22)**) in which you want to store your hot cue point. Now all hot cue buttons (**A (16)**, **B (18)**, **C (20)** or **D (22)**) which contain a cue point will light up in green.

Cueing

Cueing is the action of preparing for playback.

- 01) Press the **Cue (11)** button, the player will enter the cue mode, the playback returns to the cue point and enters pause condition, the **Cue (11)** button and the **Play/Pause (13)** button will flash. Pressing the **Play/ Pause (13)** button will start playback from the cue point.
- 02) If the **Cue (11)** button is pressed after a search operation or scan operation, the playback returns to the cue point and enters pause mode.

Note: If the **Cue (11)** button is pressed and held, playback will start from the cue point, when the button is released the player will return to the cue point and enter pause mode automatically; it allows you to check the cue point.

Frame search

Frame search is a function for monitoring the sound at a certain section of the disc and manually changing the position. Searching is used to set a starting point with precision.

- 01) Turn the **Jog wheel (10)** while in pause mode or cue mode to begin searching. The sound for one revolution of the disc is output repeatedly. The point at which the sound starts is indicated on the display.
- 02) While turning the **Jog wheel (10)**, the point from which the sound output moves is a number of frames corresponding with the number of milliseconds, and the time display on the **LCD Display (15)** also changes.
- 03) The search point moves in the forward direction when the **Jog wheel (10)** is turned clockwise. When the **Jog wheel (10)** is turned counterclockwise, the search point will move backwards.

Scanning (fast forward/fast backward)

Scanning is a function for moving quickly forward or backward while turning the **Jog wheel (10)**.

- 01) Press the **Jogmode (09)** button until the unit enters search mode. The **Search LED (07)** will light up.
- 02) Turn the **Jog wheel (10)** to start scanning. The disc moves rapidly forward or backward and the sound is audible. The current scan point is indicated on the display.
- 03) Turn the **Jog wheel (10)** clockwise to scan in the forward direction, counterclockwise to scan in the reverse direction.
- 04) Press the **Jogmode (09)** button until neither the **Search LED (07)** and **Scratch LED (08)** are lit to exit the search mode.

If the jog wheel is not used for 10 seconds while in search mode, the unit will automatically terminate search mode.

Time display

Press the **Time (28)** button to select time display mode:

- 01) Elapsed time of a track (ELAPSED).
- 02) Remaining time of a track (REMAIN).
- 03) Remaining time of the disc (TOTAL REMAIN). This display mode can only be activated if a disc is formatted as a CD.

Changing pitch of the song

There are three tools available for matching the BPM of the CD:

Use the pitch control fader to adjust the BPM.

- 01) Set the desired pitch bend range for the pitch control fader by pressing the **Pitch bend (30 or 31)** buttons. Make sure that the pitch control fader is not deactivated (no range LED lit).
- 02) Adjust the BPM by sliding the **Pitch control fader (32)** up or down.
- 03) Slide the **Pitch control fader (32)** up to decrease BPM, or down to increase BPM. The adjustment range is +/- 8%, 16% or 100% depending on the range, set up with the **Range (36)** button.

Use the pitch bend buttons to change the BPM temporarily.

- 01) The BPM increases or decreases respectively while pressing the **Pitch bend + (30)** or **Pitch bend - (31)** button.
- 02) The BPM increase depends on how long the button is held. If the button is held for about 5 seconds, the BPM will increase by 16% for **Pitch bend + (30)** or by 16% for **Pitch bend - (31)**.
If you tap the button, the BPM will only change a little so that you can change the beat slightly without an audible change in the music.
- 03) The CD will return to the BPM set with the **Pitch control fader (32)** once the **Pitch bend + (30)** and **Pitch bend - (31)** buttons are both released.

Turn the jog wheel while in jog mode to change the BPM temporarily.

- 01) Rotate the **Jog wheel (10)** clockwise during play to increase the BPM and counterclockwise to decrease the BPM. The faster you turn the wheel, the more the BPM changes. The adjustment range is +/- 16%.
- 02) Once the **Jog wheel (10)** is released, the track will return to the BPM set with the **Pitch control fader (32)**.

Program play

- 01) Press the **Play/Pause (13)** button to enter the pause mode.
- 02) Press the **Prog. (05)** button, the player will enter the program mode.
- 03) Select the desired track by rotating the **Edit encoder (03)**, confirm by pressing the track encoder. The selected track will be added to the program sequence.
- 04) Repeat the previous steps desired number of times. A maximum of 99 tracks can be programmed.
- 05) Press the **Prog. (05)** button to store the program sequence.
- 06) Use the **Play/Pause (13)** button to start/pause program play.
- 07) Press the **Prog. (05)** button again during program play to exit program play.

Press and hold the **Prog. (05)** button for more than 2 seconds to cancel the program play mode and erase all the currently saved programs.

Loop play

- 01) Press the **Loop In (17)** button to set the start point of the loop, The **Loop In (17)** button will light up, indicating that the start point is memorized.
- 02) Press the **Loop Out (19)** button to set the end point of the loop. The **Loop Out (19)** button will light up. Once the end point is set; the playback will play the loop from start point to end point repeatedly. Both the **Loop In (17)** and **Loop Out (19)** buttons will flash and RELOOP will appear on the **LCD display (15)**.
- 03) Pressing the **Reloop/Exit (21)** button will cancel the loop play function, the RELOOP indication on the **LCD display (15)** will disappear and the **Loop In (17)** and **Loop Out (19)** button will stop flashing.

Set auto loop length

- 01) Press and hold the **Rec (14)** button. It will light up in red and the display will show AUTO.
- 02) Use the **Jog wheel (10)** to setup the number of bars you plan to record for the loop.
- 03) The range is 1/32 to 32 (32/1) bars. Default the loop length is 2/1.

Auto loop play

- 01) Press the **Rec (14)** button. The **Rec (14)** will light up in red and the display will show AUTO.
- 02) Press the **Loop In (17)** button to set the loop start point, Both the **Loop In (17)** and **Loop Out (19)** buttons will flash and RELOOP will appear in the **LCD display (15)** indicating that the auto loop playback is active.
- 03) Pressing the **Reloop/Exit (21)** button will cancel the loop playback function, the RELOOP indicator on the **LCD display (15)** will disappear and the **Loop In (17)** and **Loop Out (19)** button will stop flashing.

Note: 1/1 equals one bar or 4 beats. When auto loop playback starts, the loop length is still editable by using the **Edit encoder (3)**.

Reloop

- 01) If you press the **Reloop/Exit (21)** button, the disc will return to the last selected loop.
- 02) Press the **Loop In (17)** button over and over rapidly to start the loop again and again.
- 03) Press the **Reloop/Exit (21)** button again, the loop play function is canceled, the LOOP indicator dims.

Creating a hot loop

Creating a hot loop is the action of "storing" the current loop in one of the four hot loop memories.

- 01) If you already have made a loop, skip steps 1 – 3 and proceed to step 4. Otherwise, you have to make a loop first and go to the next step.
- 02) Press the **Loop In (17)** button to set the loop start point, The **Loop In (17)** button will light up, indicating that the start point is memorized.
- 03) Press the **Loop Out (19)** button to set the loop end point. The **Loop In (17)** button will light up. After the end point is set; the playback will enter the loop play from start point to end point repeatedly. Both the **Loop In (17)** and **Loop Out (19)** buttons will flash and RELOOP will appear in the **LCD display (15)**.
- 04) Press the **Rec (14)** button, all four Memory loop buttons (**A (16)**, **B (18)**, **C (20)** or **D (22)**) will light up in red.
- 05) Press the hot loop button (**A (16)**, **B (18)**, **C (20)** or **D (22)**) in which you want to store your loop. Now all hot loop buttons (**A (16)**, **B (18)**, **C (20)** or **D (22)**) which contain a cue point will light up in orange.

Relay play (two CD players)

With the use of the supplied control cable to connect the **Relay jack (43)** connectors of two CDMP-750 devices, relay play can be performed.

- 01) Activate the relay play mode on both players by pressing their **Relay (06)** buttons. The **Relay (06)** buttons will light up in red.
- 02) Start playback on the first player.
- 03) When the current track ends, the standby player will start playback automatically.
- 04) At first player will enter pause mode at the start of the next track on its disc.
- 05) By repeating this operation, two players can be used to perform continuous relay play.
- 06) By loading new discs and choosing desired tracks on the player in standby, a continuous program of selected tracks can be played.
- 07) By setting a cue point on the standby player, a relay of any desired cue point of the selected track can be performed.

Before switching off the power

CAUTION: Do not force the disc in when the power is switched off.

Do not switch off the power, when the disc is ejecting.

Switch off the power after the disc has been ejected.

CDs

Precautions on handling compact discs

- Do not allow fingerprints, oil or dust to get to the surface of a disc. If a disc is dirty, wipe it with a soft dry cloth.
- Do not use thinner, water, record spray, electrostatic-proof chemicals or silicone-treated cloths to clean discs.
- Always handle discs carefully to prevent damaging the surface; in particular when removing a disc from its case or returning it.
- Do not bend discs.
- Do not put discs near heat sources.
- Do not enlarge the hole in the center of a disc.
- Do not write on the label (printed side) with a hard-tipped implement such as a pencil or ball point pen.
- Condensation will form if a disc is brought into a warm area from a colder one, such as outdoors in winter. Do not attempt to dry a disc with a hair dryer, etc.

Precaution on storage

- After playing a disc, always unload it from the player.
- Always store discs in a jewel case to protect from dirt or damage.
- Do not place discs in the following areas:
 - Areas exposed to sunlight for a considerable amount of time.
 - Areas subject to accumulation of dust or high humidity.
 - Areas which are affected by heat from indoor heaters, etc.

Maintenance

The DAP Audio-CD-Player CDMP-750 requires almost no maintenance. However, the unit should be kept clean.

Disconnect the mains power supply, and then wipe the cover with a damp cloth. Do not immerse in liquid. Do not use alcohol or solvents.

Keep connections clean.

Disconnect electric power, and then wipe the audio connections with a damp cloth.

Make sure that connections are thoroughly dry before linking equipment or supplying electric power.

Troubleshooting

DAP Audio-CD-Player CDMP-750

This troubleshooting guide is meant to help solve simple problems.

If a problem occurs, follow the steps below in sequence until solution is found.

- 01) If the device does not operate properly, unplug the device.
- 02) Check main power supply, all cables, connections, etc.
- 03) If all of the above appears to be in order, plug the unit in again.
- 04) If nothing happens after 30 seconds, unplug the device.
- 05) Return the device to your DAP Audio dealer.

Product Specifications

| | |
|------------------------|---|
| Quantization: | 1 bit linear/Channel, 3 Beam Laser |
| Oversampling rate: | 8 Times |
| Sampling Frequency: | 44.1 kHz |
| Frequency response: | 20 Hz to 20 kHz \pm 2db |
| T.H.D. + NOISE: | < 0,03% |
| S/N ratio (IHF-A): | > 75 dB |
| Dynamic range: | > 75 dB |
| Output level: | 1,0 Volts R.M.S. \pm 0.2V |
| Disc Type: | Standard Compact Discs, AUDIO CD, CD-R & MP3 CD-ROM (MP3 files) |
| USB Ports: | USB |
| Time Display: | Track Elapsed, Track Remain, or Total Remain |
| Text Mode: | Displays CD-TEXT and ID3 tag information. |
| Pitch control range: | \pm 8%, 16%, 100% switch |
| Power requirements: | AC 230V, 50Hz. |
| Power Consumption: | 20W |
| Operating temperature: | +5°C – +35°C |
| Weight: | 2,8 kg |
| Dimensions: | 325 x 217 x 92 mm (LxWxH) |

MP3 Format

| | DISC | USB Devices |
|-----------------------------|---|--------------------|
| Supported file extensions | | .MP3 |
| File Systems Compatible | ISO9660 | FAT , NTFS , HFS+ |
| CD-ROM sector / HD Capacity | mode-1 , mode-2 | Max. 2000Giga byte |
| Folder / directory level | | Max. 8 levels down |
| Max. number of partition | | Max. 16 Partitions |
| Max. number of folders | | Max. 999 folders |
| Max. number of files | | Max. 999 files |
| MP3 format | MPEG1 layer3 32-320kbps , f/s 32K 44.1K 48K , MPEG2 layer3 40-1600kbps , f/s 16K 22.05K 24K , (VBR/CBR) | |
| Encoding | | |
| ID-3 Tag | Ver. : V1.0 , V1.1 , V2.2 , V2.3 ,V2.4 | |

Design and product specifications are subject to change without prior notice.



Website: www.Dap-audio.info
Email: service@highlite.nl

Dimensions

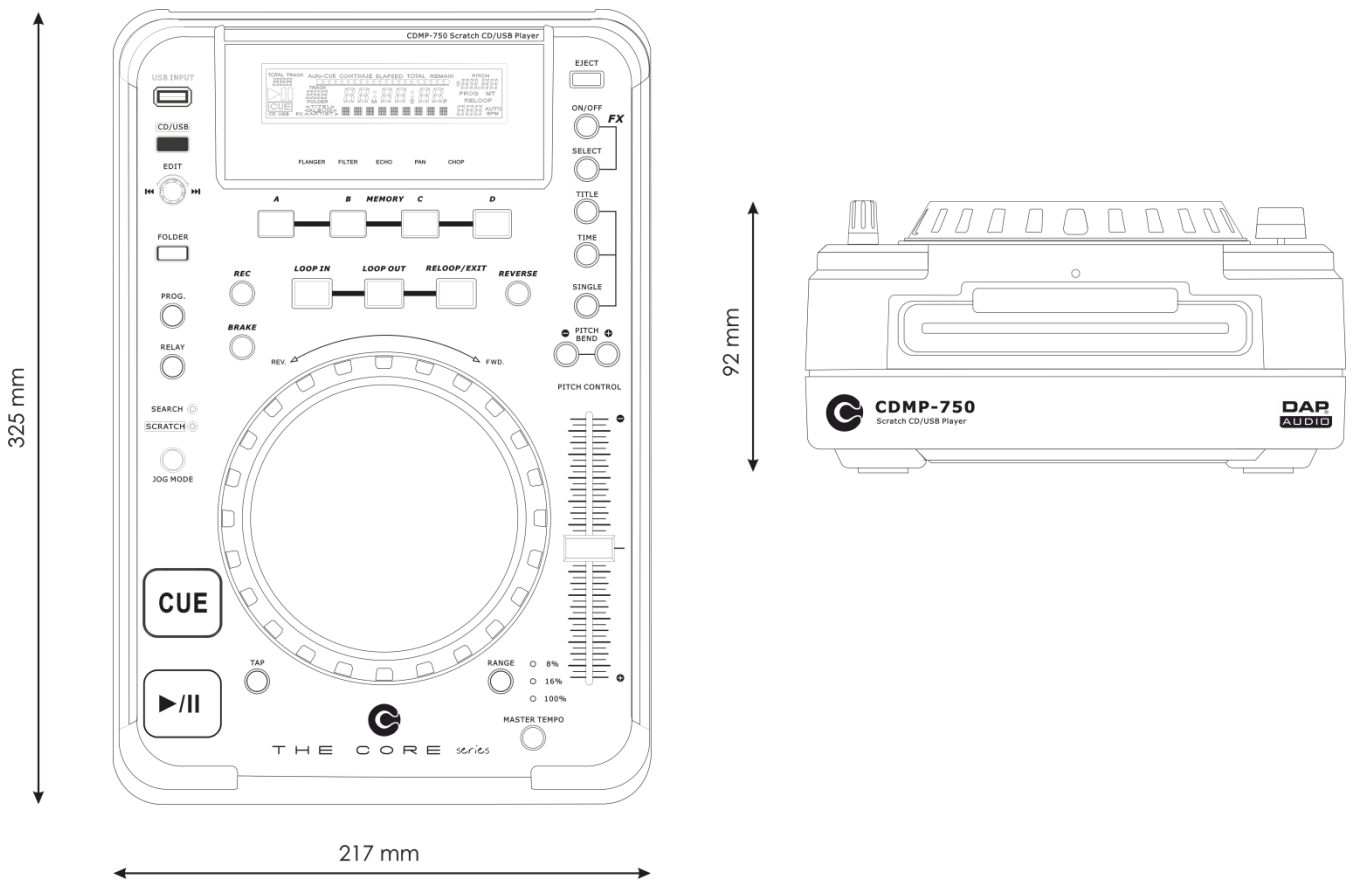



©2015 DAP Audio